

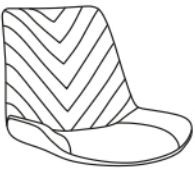

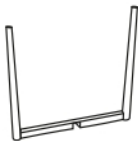



ZAINA typ 2 J-19

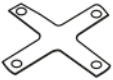

| | | | | |
|-----------------------------------------------------------------------------------------------------|-----------------------------------------------------------------------------------------------------|------------------------------------------------------------------------------------------------------------|--------------------------------------------------------------------------------------------|---------------------------------------------------------------------------------------------------|
| ①×1  | ②×1  | ③×1  | | |
| A×4  M6×13mm | B×4  M6×45mm | C×4  φ6×φ18×1.5mm | D×1  | E×1  5mm |

1

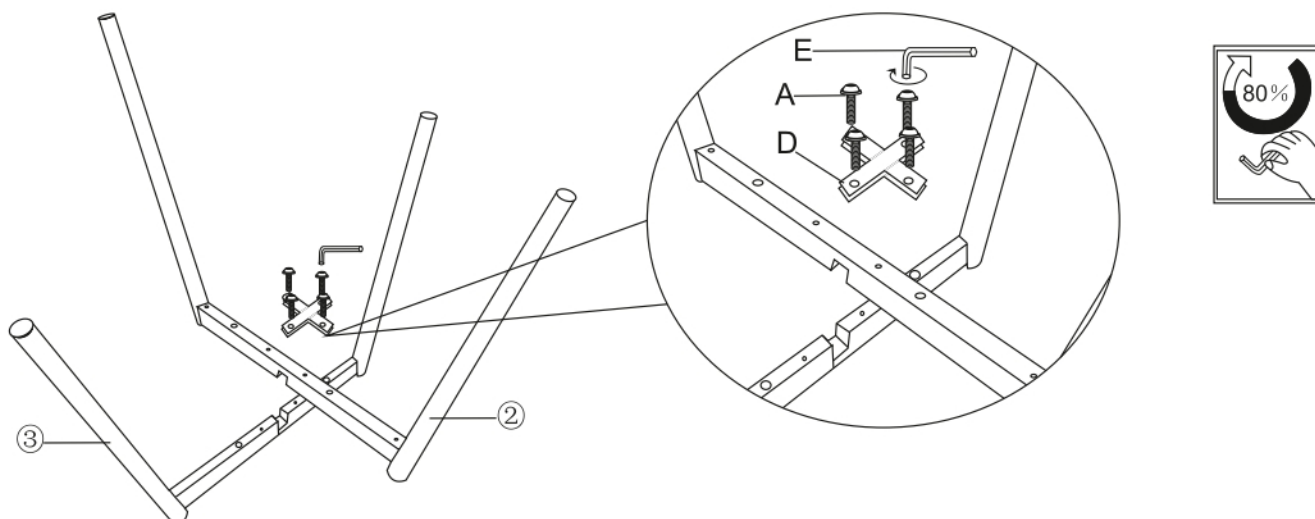

2

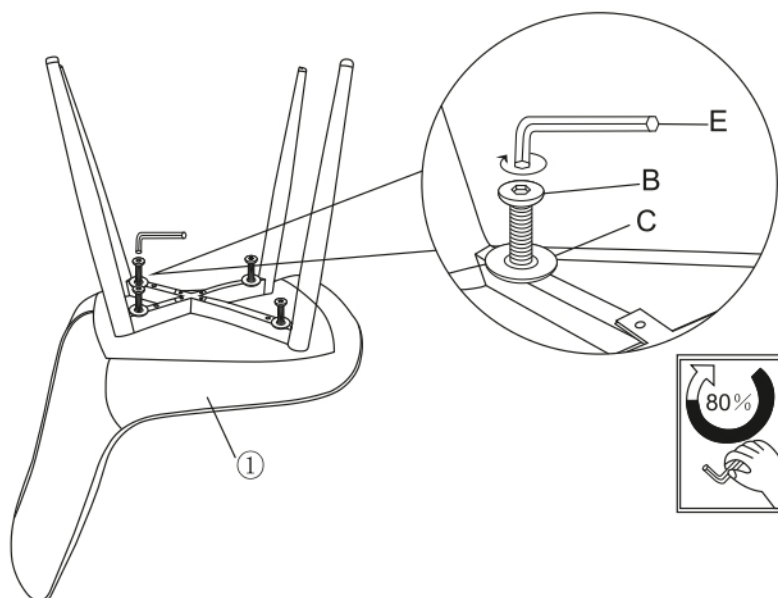

3

Položte židli na rovné místo, narovnejte ji a poté dotáhněte pevně všechny šrouby.

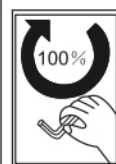

Než židli otočíte, ověřte, zda jsou všechny šrouby pevně dotáhněny. Každých 6 měsíců zkontrolujte, zda se šrouby neuvolnily, pokud se tak stalo, znovu je dotáhněte. Je běžné, že při používání se časem šrouby mohou uvolnit.